

## Digital code output type

### Description

FUJI AC series rotary switches offer a wide choice of output codes. They feature sliding Au-flashed contacts for high contact reliability. Inhibitor and parity check circuits guard against switch malfunctions caused by error signals. With only seven connections to make, these switches are an economical solution to multiposition switching needs.

### Features

- Au-flashed contacts for high contact reliability.

- The protection of operator section meets the IP65 (IEC), so these switches can be used in oil-splash environments, such as on machine tool control panels.
- A wide choice of output codes fits a broad range of applications. Available step angles are 15, 30, and 360°/26 (13.85°). Real binary code, complementary binary code, and real gray code are available.
- Switches are available with connectors or with lock rings for easy handling.
- Stopper screw positions are user selectable.

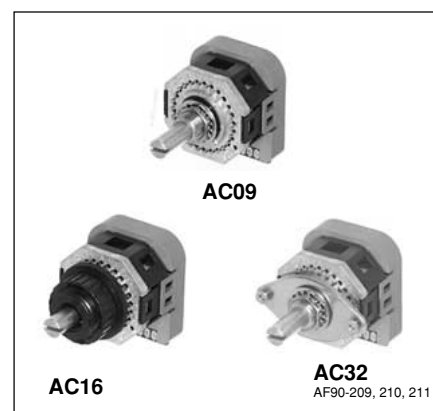

### Ratings

Volts	Operational current (A) (resistive load)
50V AC	0.05
5V AC	0.5
25V DC	0.05
5V DC	0.25

### Performance

Rated insulation voltage	60V
Operating temperature	-20 to +70°C
Humidity	45 to 85%RH (non condensation)
Service life	Mechanical: 50,000 operations Electrical: 50,000 operations
Dielectric strength	Between terminals: 250V AC, 1 minute Between terminals and ground: 1500V AC, 1 minute
Insulation resistance	Between terminals: 500MΩ or more Between terminals and ground: 5,000MΩ or more
Degree of protection (operator section)	IP65 (IEC)

### Type number nomenclature

**AC 09 – C Z 0 / 25 L1 E A01 / 0007**

#### Basic type

#### Mounting

09: M9 nut  
16: M16 adapter  
32: Adapter  
(32mm mounting pitch)

#### Type of code

R: Real binary code  
C: Complementary binary code  
G: Real gray code

#### Angle of step

Angle	Setting position
X: 30°	0 to 11
W: 360°/13 (27.69°)	0 to 12
Y: 15°	0 to 23
Z: 360°/26 (13.85°)	0 to 25

#### Start position

Available step angle
0 to 11: 30°
0 to 12: 360°/13 (27.69°)
0 to 23: 15°
0 to 25: 360°/26 (13.85°)

#### End position

Available step angle
0 to 11: 30°
0 to 12: 360°/13 (27.69°)
0 to 23: 15°
0 to 25: 360°/26 (13.85°)

#### With or without lock ring

Blank: Without lock ring  
0007: With lock ring  
0009: With adhesive lock ring

#### With or without connector

Blank: 8-terminal, without connector  
A01: 8-terminal, with right-angle connector  
A02: 8-terminal, with straight connector  
B00: 7-terminal, without connector  
B01: 7-terminal, with right-angle connector  
B02: 7-terminal, with straight connector

#### With or without stopper screw

Blank: With stopper screw  
E: Without stopper screw

#### Length of shaft (mm)

	AC09	AC16	AC32
L1:	16	—	14.5
L2:	18	—	16.5
L3:	20	—	18.5
L4:	22	19.5	20.5

Note: When shorter action than the maximum range of switch action is used, stopper screws are used. However, stopper screws are not used if the maximum action range is used when either 15° (symbol Y) or 360°/26 (symbol Z) is specified.

# Rotary Switches

## AC09, 16 and 32

### • M9 nut mounting

Angle of step	Connector	Lock ring	Type*1 *2 *3		
			Real binary code	Complementary binary code	Real gray code
30°	Without connector	Without lock ring With lock ring With adhesive lock ring	AC09-RX□□( )■ AC09-RX□□( )■/0007 AC09-RX□□( )■/0009	AC09-CX□□( )■ AC09-CX□□( )■/0007 AC09-CX□□( )■/0009	AC09-GX□□( )■ AC09-GX□□( )■/0007 AC09-GX□□( )■/0009
	With right angle connector	Without lock ring With lock ring With adhesive lock ring	AC09-RX□□( )■01 AC09-RX□□( )■01/0007 AC09-RX□□( )■01/0009	AC09-CX□□( )■01 AC09-CX□□( )■01/0007 AC09-CX□□( )■01/0009	AC09-GX□□( )■01 AC09-GX□□( )■01/0007 AC09-GX□□( )■01/0009
	With straight connector	Without lock ring With lock ring With adhesive lock ring	AC09-RX□□( )■02 AC09-RX□□( )■02/0007 AC09-RX□□( )■02/0009	AC09-CX□□( )■02 AC09-CX□□( )■02/0007 AC09-CX□□( )■02/0009	AC09-GX□□( )■02 AC09-GX□□( )■02/0007 AC09-GX□□( )■02/0009
360°/13 (27.69°)	Without connector	Without lock ring With lock ring With adhesive lock ring	AC09-RW□□( )■ AC09-RW□□( )■/0007 AC09-RW□□( )■/0009	AC09-CW□□( )■ AC09-CW□□( )■/0007 AC09-CW□□( )■/0009	
	With right angle connector	Without lock ring With lock ring With adhesive lock ring	AC09-RW□□( )■01 AC09-RW□□( )■01/0007 AC09-RW□□( )■01/0009	AC09-CW□□( )■01 AC09-CW□□( )■01/0007 AC09-CW□□( )■01/0009	
	With straight connector	Without lock ring With lock ring With adhesive lock ring	AC09-RW□□( )■02 AC09-RW□□( )■02/0007 AC09-RW□□( )■02/0009	AC09-CW□□( )■02 AC09-CW□□( )■02/0007 AC09-CW□□( )■02/0009	
15°	Without connector	Without lock ring With lock ring With adhesive lock ring	AC09-RY□□( )■ AC09-RY□□( )■/0007 AC09-RY□□( )■/0009	AC09-CY□□( )■ AC09-CY□□( )■/0007 AC09-CY□□( )■/0009	AC09-GY□□( )■ AC09-GY□□( )■/0007 AC09-GY□□( )■/0009
	With right angle connector	Without lock ring With lock ring With adhesive lock ring	AC09-RY□□( )■01 AC09-RY□□( )■01/0007 AC09-RY□□( )■01/0009	AC09-CY□□( )■01 AC09-CY□□( )■01/0007 AC09-CY□□( )■01/0009	AC09-GY□□( )■01 AC09-GY□□( )■01/0007 AC09-GY□□( )■01/0009
	With straight connector	Without lock ring With lock ring With adhesive lock ring	AC09-RY□□( )■02 AC09-RY□□( )■02/0007 AC09-RY□□( )■02/0009	AC09-CY□□( )■02 AC09-CY□□( )■02/0007 AC09-CY□□( )■02/0009	AC09-GY□□( )■02 AC09-GY□□( )■02/0007 AC09-GY□□( )■02/0009
360°/26 (13.85°)	Without connector	Without lock ring With lock ring With adhesive lock ring	AC09-RZ□□( )■ AC09-RZ□□( )■/0007 AC09-RZ□□( )■/0009	AC09-CZ□□( )■ AC09-CZ□□( )■/0007 AC09-CZ□□( )■/0009	AC09-GZ□□( )■ AC09-GZ□□( )■/0007 AC09-GZ□□( )■/0009
	With right angle connector	Without lock ring With lock ring With adhesive lock ring	AC09-RZ□□( )■01 AC09-RZ□□( )■01/0007 AC09-RZ□□( )■01/0009	AC09-CZ□□( )■01 AC09-CZ□□( )■01/0007 AC09-CZ□□( )■01/0009	AC09-GZ□□( )■01 AC09-GZ□□( )■01/0007 AC09-GZ□□( )■01/0009
	With straight connector	Without lock ring With lock ring With adhesive lock ring	AC09-RZ□□( )■02 AC09-RZ□□( )■02/0007 AC09-RZ□□( )■02/0009	AC09-CZ□□( )■02 AC09-CZ□□( )■02/0007 AC09-CZ□□( )■02/0009	AC09-GZ□□( )■02 AC09-GZ□□( )■02/0007 AC09-GZ□□( )■02/0009

#### Notes:

\*1 Replace the □□ marks by the Start and End positions

Step angle	30°	360°/13	15°	360°/26
Start and End positions	0 to 11	0 to 12	0 to 23	0 to 25

\*2 Replace the ( ) mark by the shaft length code

L1: 16mm L2: 18mm L3: 20mm L4: 22mm

\*3 Replace the ■ mark by the connector

Blank: 8-terminal, without connector  
 A01: 8-terminal, with right angle connector  
 A02: 8-terminal, with straight connector  
 B00: 7-terminal, without connector  
 B01: 7-terminal, with right angle connector  
 B02: 7-terminal, with straight connector

• M16 adapter mounting

Angle of step	Connector	Type*1 *2		
		Real binary code	Complementary binary code	Real gray code
30°	Without connector	AC16-RX□/□L4■	AC16-CX□/□L4■	AC16-GX□/□L4■
	With right angle connector	AC16-RX□/□L4■01	AC16-CX□/□L4■01	AC16-GX□/□L4■01
	With straight connector	AC16-RX□/□L4■02	AC16-CX□/□L4■02	AC16-GX□/□L4■02
360°/13 (27.69°)	Without connector	AC16-RW□/□L4■	AC16-CW□/□L4■	
	With right angle connector	AC16-RW□/□L4■01	AC16-CW□/□L4■01	
	With straight connector	AC16-RW□/□L4■02	AC16-CW□/□L4■02	
15°	Without connector	AC16-RY□/□L4■	AC16-CY□/□L4■	AC16-GY□/□L4■
	With right angle connector	AC16-RY□/□L4■01	AC16-CY□/□L4■01	AC16-GY□/□L4■01
	With straight connector	AC16-RY□/□L4■02	AC16-CY□/□L4■02	AC16-GY□/□L4■02
360°/26 (13.85°)	Without connector	AC16-RZ□/□L4■	AC16-CZ□/□L4■	AC16-GZ□/□L4■
	With right angle connector	AC16-RZ□/□L4■01	AC16-CZ□/□L4■01	AC16-GZ□/□L4■01
	With straight connector	AC16-RZ□/□L4■02	AC16-CZ□/□L4■02	AC16-GZ□/□L4■02

Notes:

\*1 Replace the □□ marks by the Start and End positions

Step angle	30°	360°/13	15°	360°/26
Start and End positions	0 to 11	0 to 12	0 to 23	0 to 25

\*2 Replace the ■ mark by the connector

Blank: 8-terminal, without connector  
A01: 8-terminal, with right angle connector  
A02: 8-terminal, with straight connector  
B00: 7-terminal, without connector  
B01: 7-terminal, with right angle connector  
B02: 7-terminal, with straight connector

• Adaptor mounting (32mm mounting pitch)

Angle of step	Connector	Type*1 *2 *3		
		Real binary code	Complementary binary code	Real gray code
30°	Without connector	AC32-RX□/□( )■	AC32-CX□/□( )■	AC32-GX□/□( )■
	With right angle connector	AC32-RX□/□( )■01	AC32-CX□/□( )■01	AC32-GX□/□( )■01
	With straight connector	AC32-RX□/□( )■02	AC32-CX□/□( )■02	AC32-GX□/□( )■02
360°/13 (27.69°)	Without connector	AC32-RW□/□( )■	AC32-CW□/□( )■	
	With right angle connector	AC32-RW□/□( )■01	AC32-CW□/□( )■01	
	With straight connector	AC32-RW□/□( )■02	AC32-CW□/□( )■02	
15°	Without connector	AC32-RY□/□( )■	AC32-CY□/□( )■	AC32-GY□/□( )■
	With right angle connector	AC32-RY□/□( )■01	AC32-CY□/□( )■01	AC32-GY□/□( )■01
	With straight connector	AC32-RY□/□( )■02	AC32-CY□/□( )■02	AC32-GY□/□( )■02
360°/26 (13.85°)	Without connector	AC32-RZ□/□( )■	AC32-CZ□/□( )■	AC32-GZ□/□( )■
	With right angle connector	AC32-RZ□/□( )■01	AC32-CZ□/□( )■01	AC32-GZ□/□( )■01
	With straight connector	AC32-RZ□/□( )■02	AC32-CZ□/□( )■02	AC32-GZ□/□( )■02

Notes:

\*1 Replace the □□ marks by the Start and End positions

Step angle	30°	360°/13	15°	360°/26
Start and End positions	0 to 11	0 to 12	0 to 23	0 to 25

\*2 Replace the ( ) mark by the shaft length  
L1: 14.5mm L2: 16.5mm L3: 18.5mm L4: 20.5mm

\*3 Replace the ■ mark by the connector

Blank: 8-terminal, without connector  
A01: 8-terminal, with right angle connector  
A02: 8-terminal, with straight connector  
B00: 7-terminal, without connector  
B01: 7-terminal, with right angle connector  
B02: 7-terminal, with straight connector



## Accessories

### Lead wire with connector (8-terminal)



Length of lead wire (m)	Type	Mass (g)
0.5	ACX011-805	11
1.0 (Standard)	ACX011-810	19
2.0	ACX011-820	33

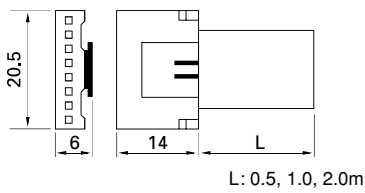

### Lock ring



	Type	Mass (g)
Lock ring (inserted)	ACX001	2
Lock ring (sealed)	ACX001A	5

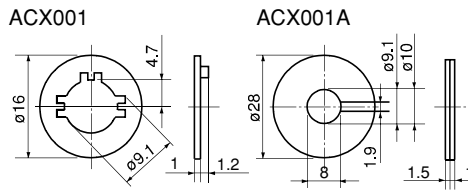

## Dimensions, mm AC09

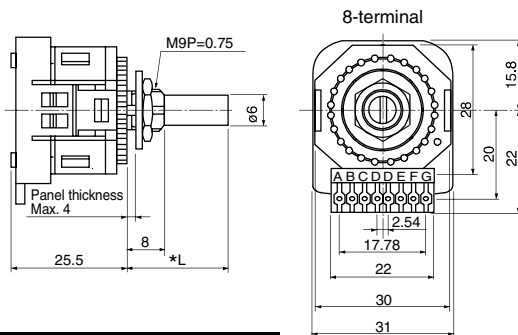

Shaft length *	L1	L2	L3	L4
	16	18	20	22
Mass (g)				
Without connector	41	42	43	44
With connector	42	43	44	45

### Panel cutting

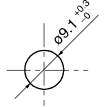

### AC09 (with connector)

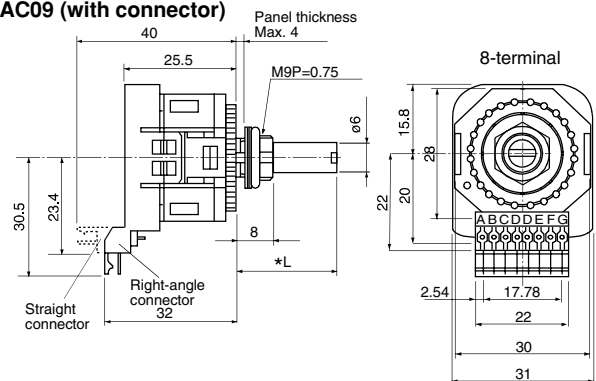

### Panel cutting

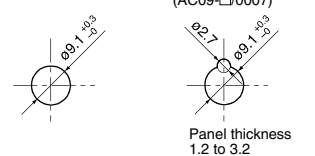

## AC16

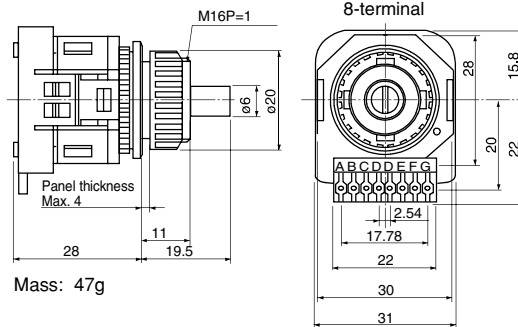

Mass: 47g

### Panel cutting

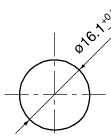

## AC32

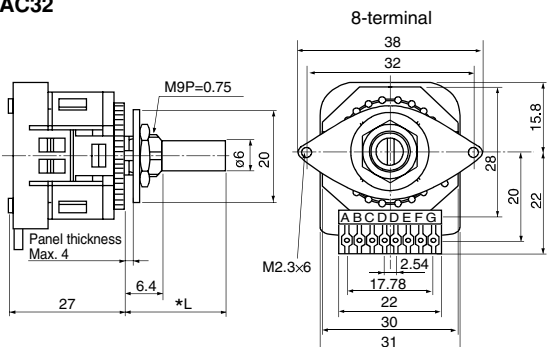

Shaft length *	L1	L2	L3	L4
	14.5	16.5	18.5	20.5
Mass (g)	47	48	49	50

### Panel cutting

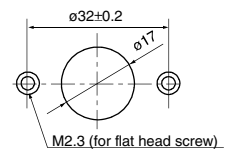

# Rotary Switches AC09, 16 and 32

## ■ Installation

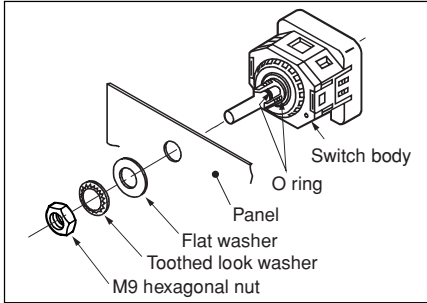

### AC09

Pass the switch body through the hole from the back of the panel, and secure it by tightening the hexagonal nut with a flat washer and a toothed lock washer.

The recommended tightening torque for the hexagonal nut is 1.5 to 2N·m.

Insert the lock ring (ACX001) between the panel and the flat washer, and the adhesive lock ring (ACX001A) between the switch body and the panel.

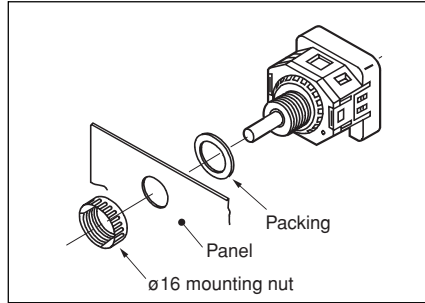

### AC16

Pass the switch body with a bezel through the hole from the back of the panel, and secure it with a  $\phi 16$  mounting nut. The recommended tightening torque for the nut is 0.6 to 1N·m.

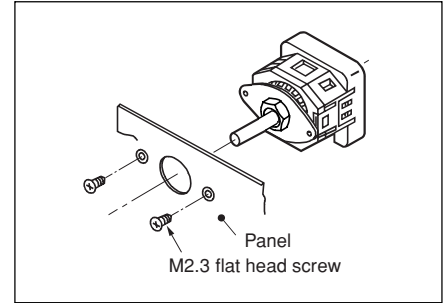

### AC32

Pass the switch body through the hole from the back of the panel, and secure it with two flat head screws from the face of the panel. The recommended tightening torque for the flat head screws is 0.3 to 0.5N·m.

## ■ Notes on use

### 1. Connecting wires

Note the following points when soldering:

- The power of the soldering iron must not be over 30W.
- Use solder with resin flux core.
- Complete soldering within 5 seconds if using a 30W soldering iron, or within 10 seconds if using a 20W soldering iron.

### 2. Note on the case linkage

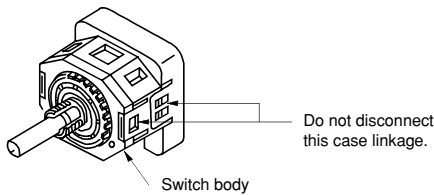

### 4. Stopper screw positions

Insert stopper screws into the switch body holes marked with letters, as shown in the insertion example on the right. These tables below show that the start position stopper screw is inserted in the hole on the left of the position setting and the end positions stopper screw is inserted in the hole on the right.

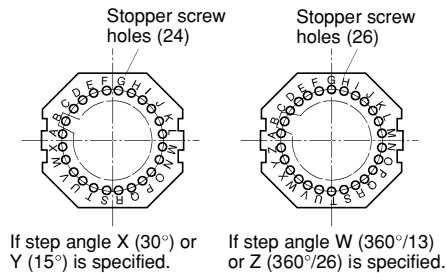

### 3. Number of stopper screws shipped

- AC09 and AC32
  - Step angle: 30° (symbol X)  
Positions 0/11 (0 to 11): one screw. User-selectable start and stop positions: two screws (one for start position, one for end position).
  - Step angle: 15° (symbol Y)  
Positions 0/22 (0 to 22): one screw. User-selectable start and stop positions: two screws (one for start position, one for end position).
  - Step angle: 360°/26 (symbol Z)  
Positions 0/24 (0 to 24): one screw. User-selectable start and stop positions: two screws (one for start position, one for end position).
- AC16  
Customers can specify the stopper screw positions. The switch is then shipped with stopper screws already in the specified positions.

### 5. Installing a stopper screw

The maximum tightening torque for a stopper screw is 0.1N·m. Screw the stopper screw into position until it hits the body frame rib. Do not overtighten the screw.

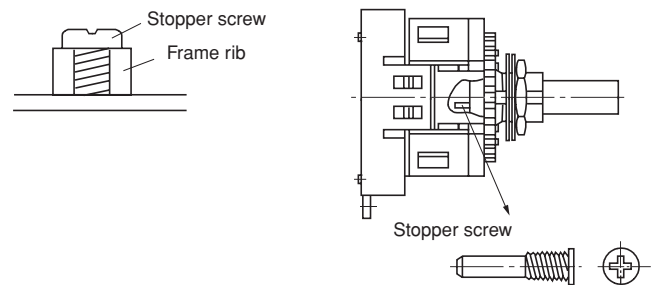

Insertion example 1

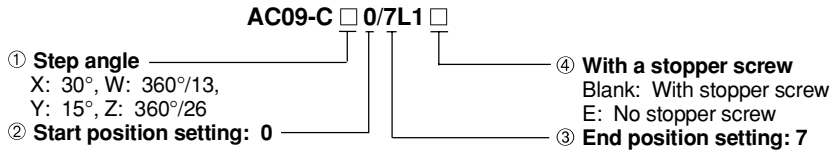

• If symbol ① (step angle) is X-----type AC09-CX0/7L1:

Insert the start side stopper screw in hole A and the end side screw in hole Q.

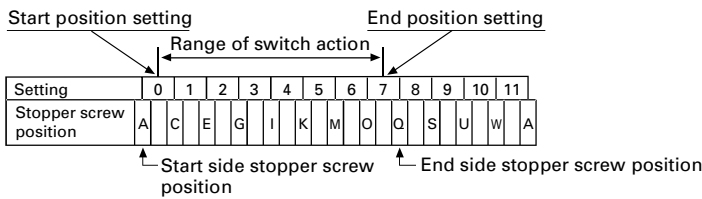

• If symbol ① (step angle) is W-----type AC09-CW0/7L1:

Insert the start side stopper screw in hole A and the end side screw in hole Q.

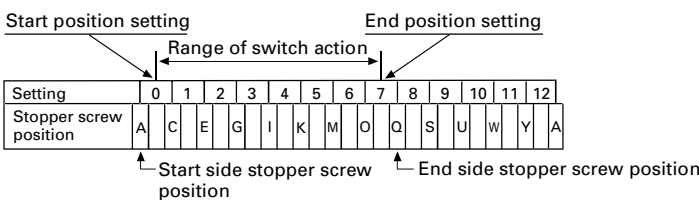

• If symbol ① (step angle) is Y-----type AC09-CY0/7L1:

Insert the start side stopper screw in hole A and the end side screw in hole J.

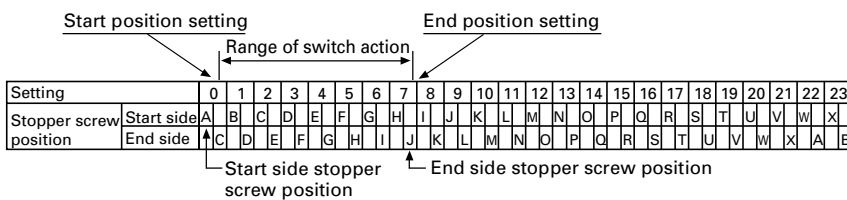

Notes: 1. If the range of action is designated as 0/22 (0 to 22), insert a stopper screw into hole A only.  
2. If the range of action is designated as 0/23 (0 to 23), no stopper screws are inserted (symbol ④ is E).

• If symbol ① (step angle) is Z-----type AC09-CZ0/7L1:

Insert the start side stopper screw in hole A and the end side screw in hole J.

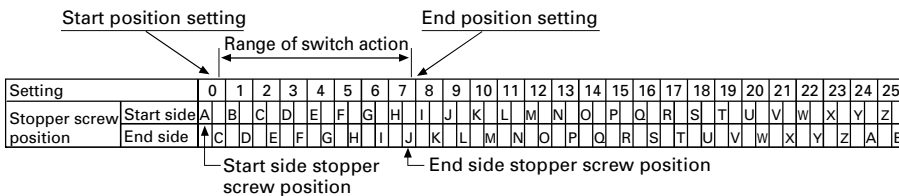

Notes: 1. If the range of action is designated as 0/24 (0 to 24), insert a stopper screw in hole A only.  
2. If the range of action is designated as 0/25 (0 to 25), no stopper screws are inserted (symbol ④ is E).

Insertion example 2

